

WORK TABLE & BACK BOARD ASSEMBLY INSTRUCTIONS

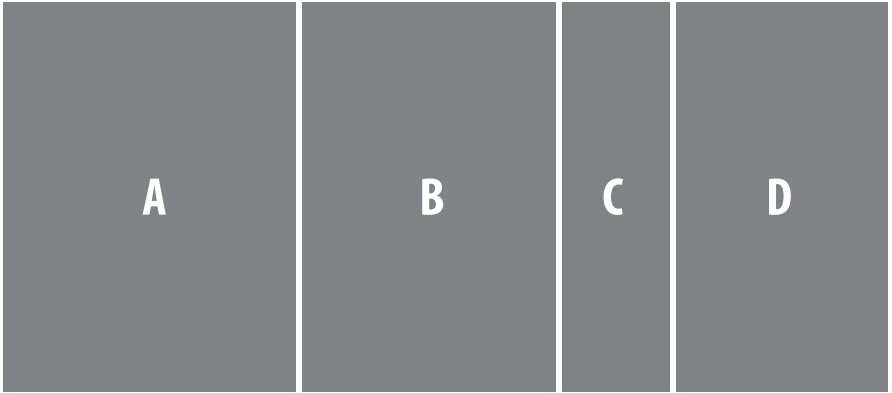

380 Markland Street
Markham, ON L6C 1T6
www.trademarktools.ca

CONTENTS OF THE WORK TABLE & BACKBOARD CARTON



- A.** Bottom board (1198 x 598 x 6 mm)
- B.** Table -top board (1198 x 598 x 15 mm)
- C.** Holed back board (1200 x 217 x 6 mm)
- D.** Peg board (1188 x 607 x 4.5 mm)

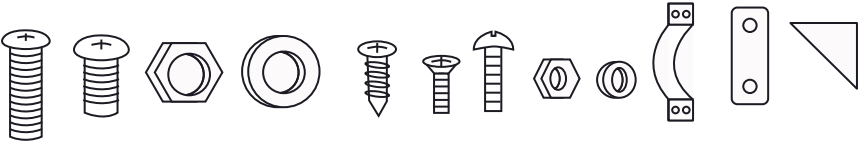

1. Bolt M6 x 15 mm (8pcs)
2. Bolt M6 x 10 mm (63pcs)
3. Nut M6 (71pcs)
4. Washer M6 (71pcs)
5. Wood Screw (4pcs)
6. Bolt M x 10 mm (8pcs) (for handle)
7. Bolt M4 x 12 mm (10pcs)
8. Nut (18pcs)
9. Washer M4 x 14 mm (18pcs)
10. Drawer Handle (2pcs)
11. Reinforced metal plate (1pc)
12. Feet plastic protector (4pcs)

CONTENTS OF THE WORK TABLE & BACKBOARD CARTON (cont.)

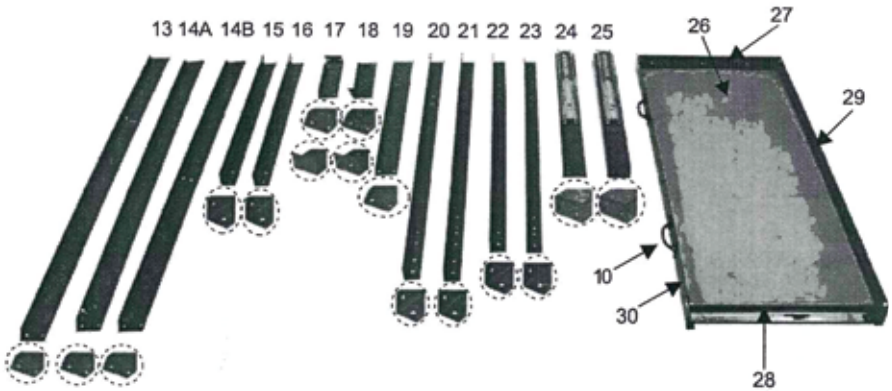

- 13. Top rail 1198 mm (2pcs)
- 14A. Cross member 1186 mm (3pcs)
- 14B. Cross member (with holes in centre) 1186 mm (2pcs)
- 15. Left holder back board support 640 mm (1pc)
- 16. Right holder back board support 640 mm (1pc)
- 17. Left top cantilever arm 215 mm (1pc)
- 18. Right top cantilever arm 215 mm (1pc)
- 19. Side rail 586 mm (4pcs)
- 20. Left rear leg 996 mm (1pc)
- 21. Right rear leg 996 mm (1pc)
- 22. Left front leg 900 mm (1pc)
- 23. Right front leg 900 mm (1pc)
- 24. Left guide rail 599.4 mm (1pc) (for mounting drawer)
- 25. Right guide rail 599.4 mm (1pc) (for mounting drawer)
- 26. Drawer bottom (1pc) (drawer size 1093 x 448 mm)
- 27. Drawer left side panel (1pc)
- 28. Drawer right side panel (1pc)
- 29. Drawer rear panel (1pc)
- 30. Drawer front panel (1pc)

TOOL BOARD ASSEMBLY

STEP 1

Place the left holed back board support (15) and the right hole back board support (16) on a level surface.



STEP 2

Mount a cross member (13) between the holed back board supports. Fasten the corners using bolts, washers & nuts provided.



STEP 3

Place the holed back board (D) in between the frames (as shown). Use two M6 x 15 mm bolts (type 1), washers & nuts at the top to fasten the holed back board (D) to the frame.

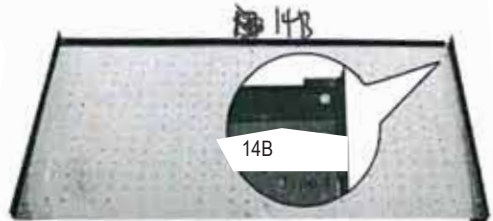

STEP 4

Position the left top cantilever arm (17) and the right top cantilever arm (18) in the corners of the frame.



STEP 5

Mount the top rail (13) between the two top cantilever arms. Fasten the corners of the frame using the bolts, washers and nuts as shown.



STEP 6

Mount the top board (C) on top of the frame using the wood screws (type 5).



DRAWER ASSEMBLY

STEP 1

Attach the drawer handle (10) to the drawer front panel (30) using the bolts, washers and nuts (type 7).

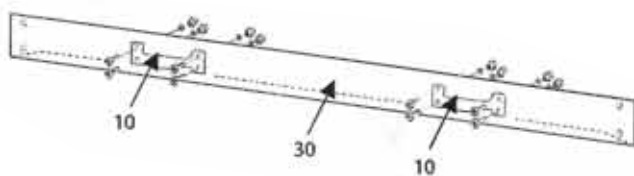

STEP 2

Assemble the drawer unit as shown below, and use bolts and nuts to fasten the corners.

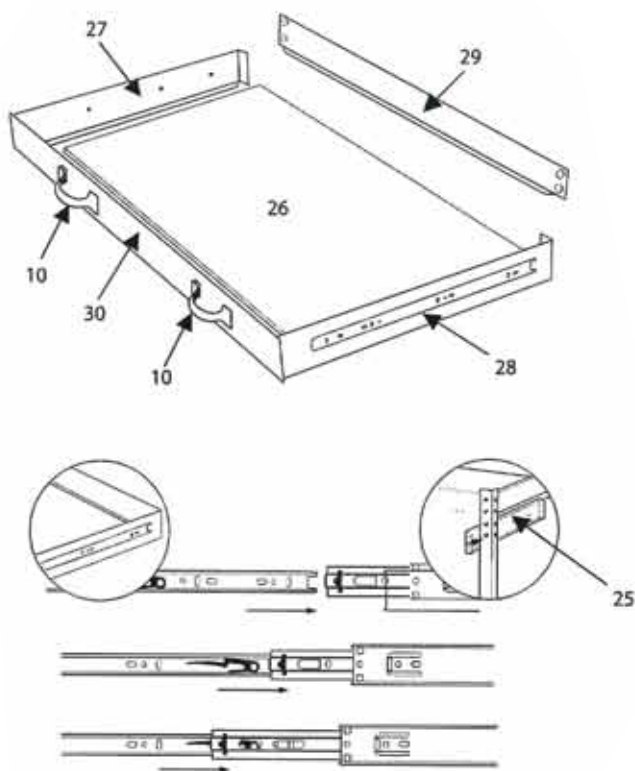

WORK STATION ASSEMBLY

STEP 1

Place left rear leg (20) and the right leg (21) on a level surface.



STEP 2

Connect the two rear legs, at the bottom, with a cross member (14A).

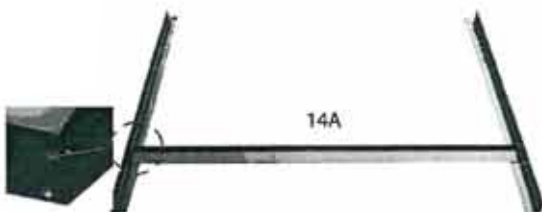

STEP 3

Mount another cross member (14B) at the top of the legs.

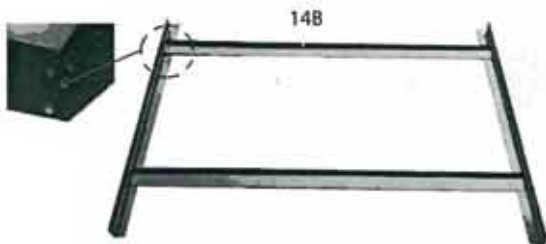

WORK STATION ASSEMBLY (cont.)

STEP 4

Place the four side rails (19) on the rear legs.

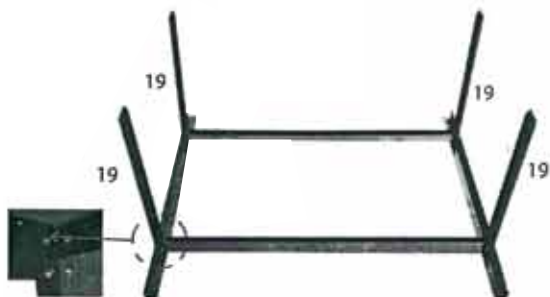

STEP 5

Mount the left guide rail (24) and the right guide rail (25) on the rear legs, at the top, as shown.

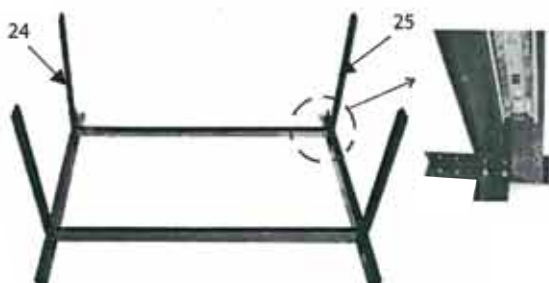

STEP 6

Place the left front leg (22) and the right front leg (23) on the side rails.

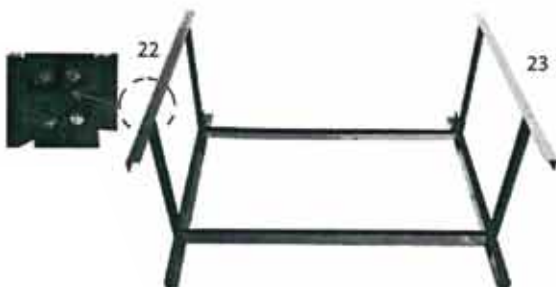

WORK STATION ASSEMBLY (cont.)

STEP 7

Mount a cross member (14A) between the front legs (on the upper frame) and secure with bolts and nuts.



STEP 8

Mount a second cross member (14A) between the front legs (on the lower frame) and secure with bolts and nuts. Place the feet plastic protectors (12) on the base of each foot.

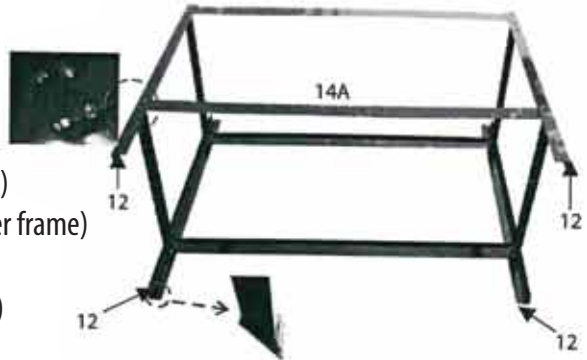

STEP 9

Place the work station in the upright position.



WORK STATION ASSEMBLY (cont.)

STEP 10

Slide the assembled drawer into place along the guide rails (24) and (25)



STEP 11

Place the bottom board (A) on the lower part of the work station (as shown).



STEP 12

Place the table top board (B) on the top section of the work station.



WORK STATION ASSEMBLY (cont.)

STEP 13

Mount the assembled Tool Board on the table and securely fasten using M6 x 15 mm bolts (type1) through the openings in the holed board.

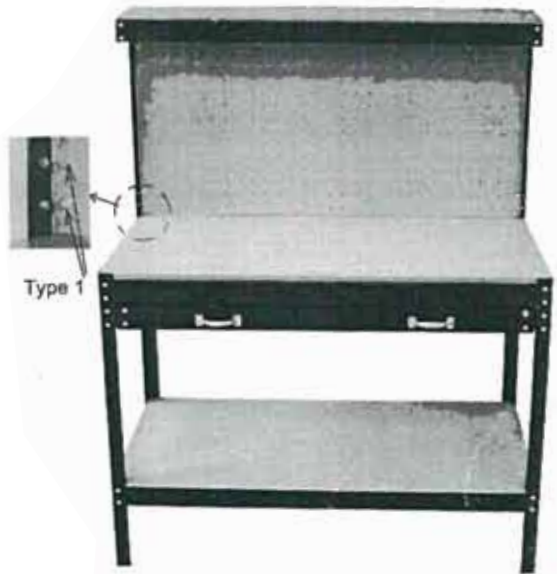

STEP 14

Fix the reinforced metal plate (11) onto the back lower part of the assembled Table Top Board and secure tightly with the bolts, washers and nuts provided.

